



# Summer Finale at the California Ranch Company

## Show Pattern Book

CALIZONA & SPOTTED VALLEY  
APPALOOSA HORSE SHOW

| August 8 & 9, 2020 |

# Showmanship at Halter

#13 Youth 18+U  
#14 Non-Pro

#36 NonPro 35+Over #37 NonPro Masters  
#16 NonPro Miniature Horse

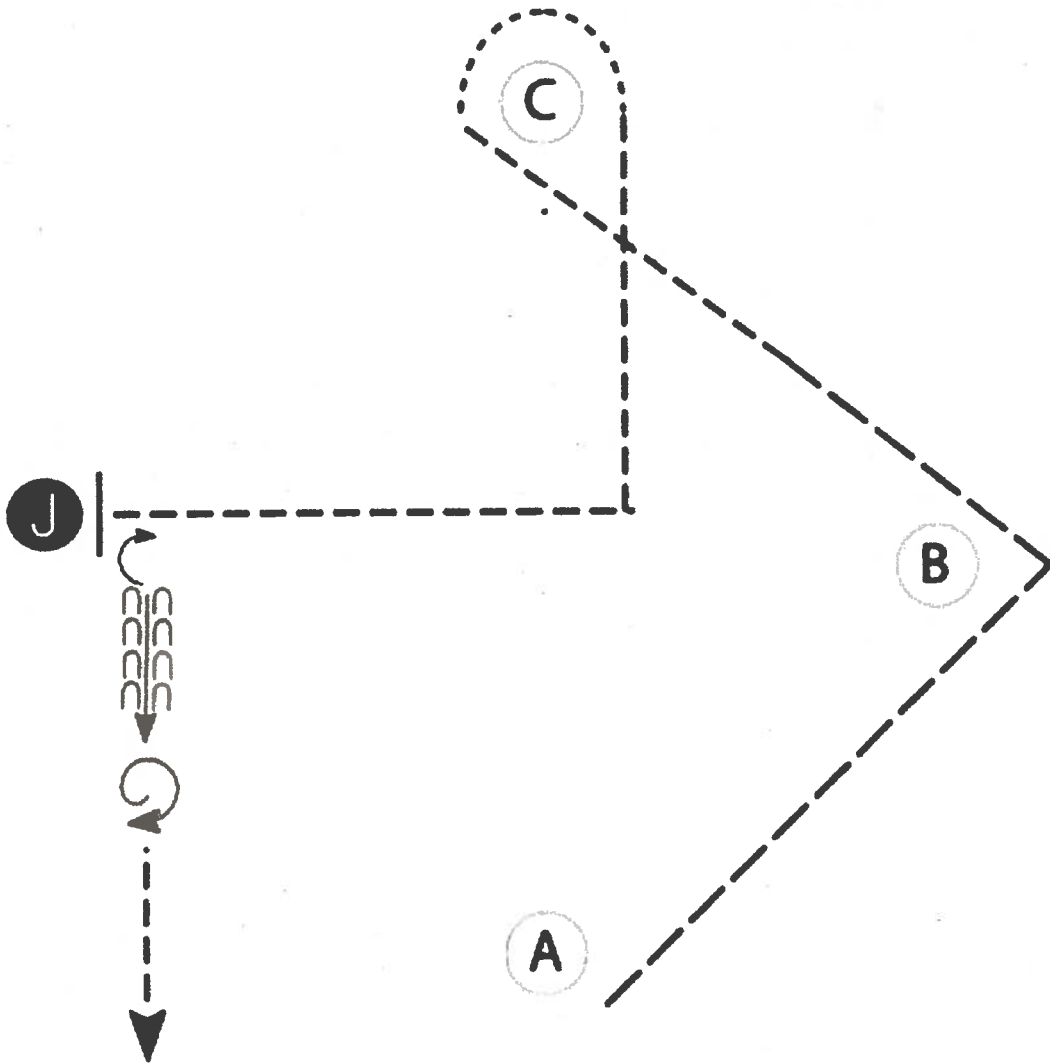

1. Be ready and set up at A.
2. Extend the trot from A to halfway between B and C.
3. Slow to the trot and continue to C.
4. At C, break to a walk and walk around C.
5. Trot a square corner from C to the Judge and stop.
6. Set up for inspection.
7. After inspection, pivot 90 degrees, back one horse length and pivot 540 degrees.
8. Trot straight away. Pattern is complete.

Walk	-----
Trot	-----
Back	← ⏏⏏⏏ ⏏⏏⏏
Marker	⊙ B
Judge	● J

WWW.HORSESNOWPATTERNS.COM

WWW.HORSESNOWPATTERNS.COM

#15 W/T 10+ Under  
 #25 Nov NP  
 #26 Nov Youth  
 #27 Yth W/T 11-18

# Showmanship Novice & Walk/Trot

WWW.HORSESHOWPATTERNS.COM

WWW.HORSESHOWPATTERNS.COM

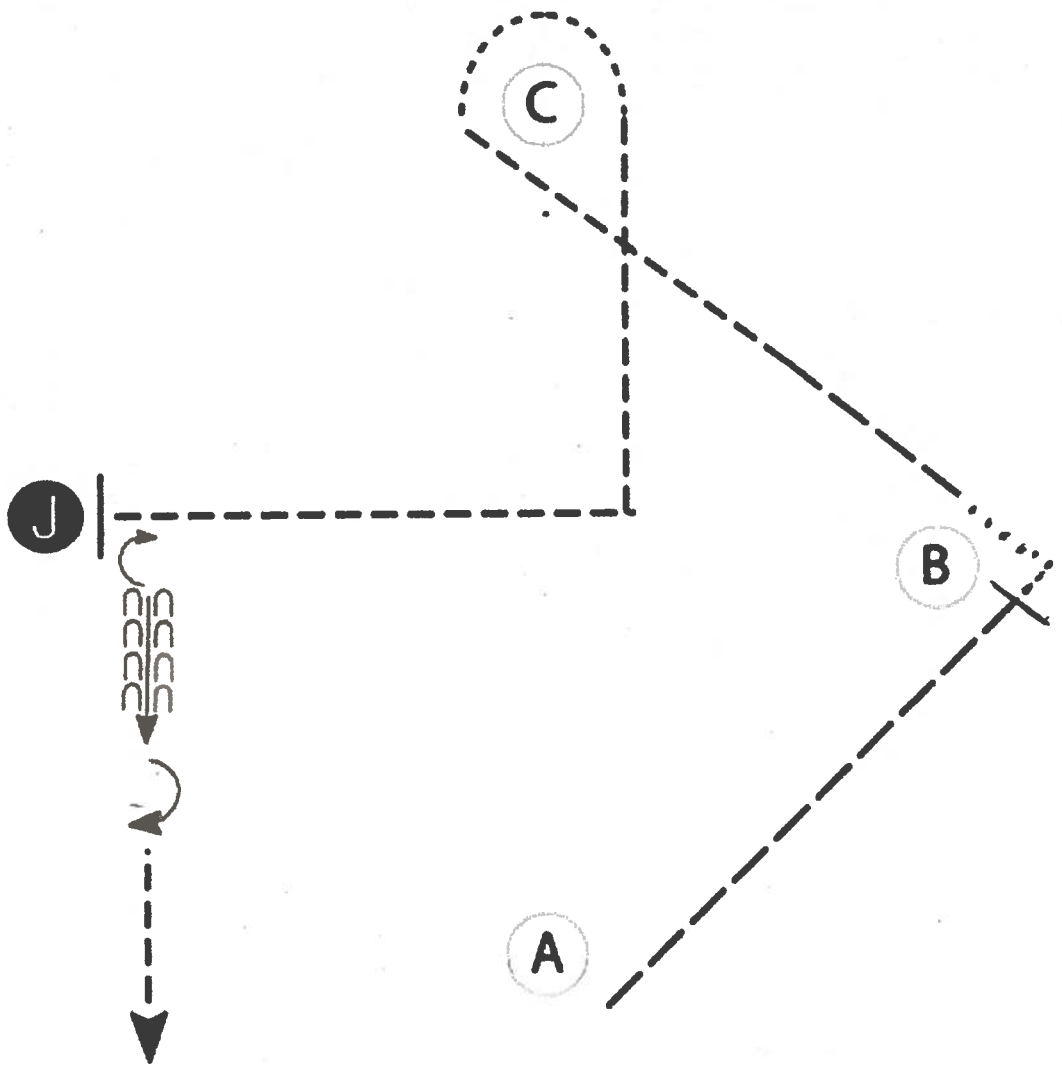

1. Be ready and set up at A.
2. Extend the trot from A to B; Stop. Walk square turn
3. Trot and continue to C.
4. At C, break to a walk and walk around C.
5. Trot a square corner from C to the Judge and stop.
6. Set up for inspection.
7. After inspection, pivot 90 degrees, back one horse length and pivot 180 degrees.
8. Trot straight away. Pattern is complete.

Walk	.....
Trot	-----
Back	← cccc cccc
Marker	⊙ B
Judge	● J

# Champion of Champions Showmanship

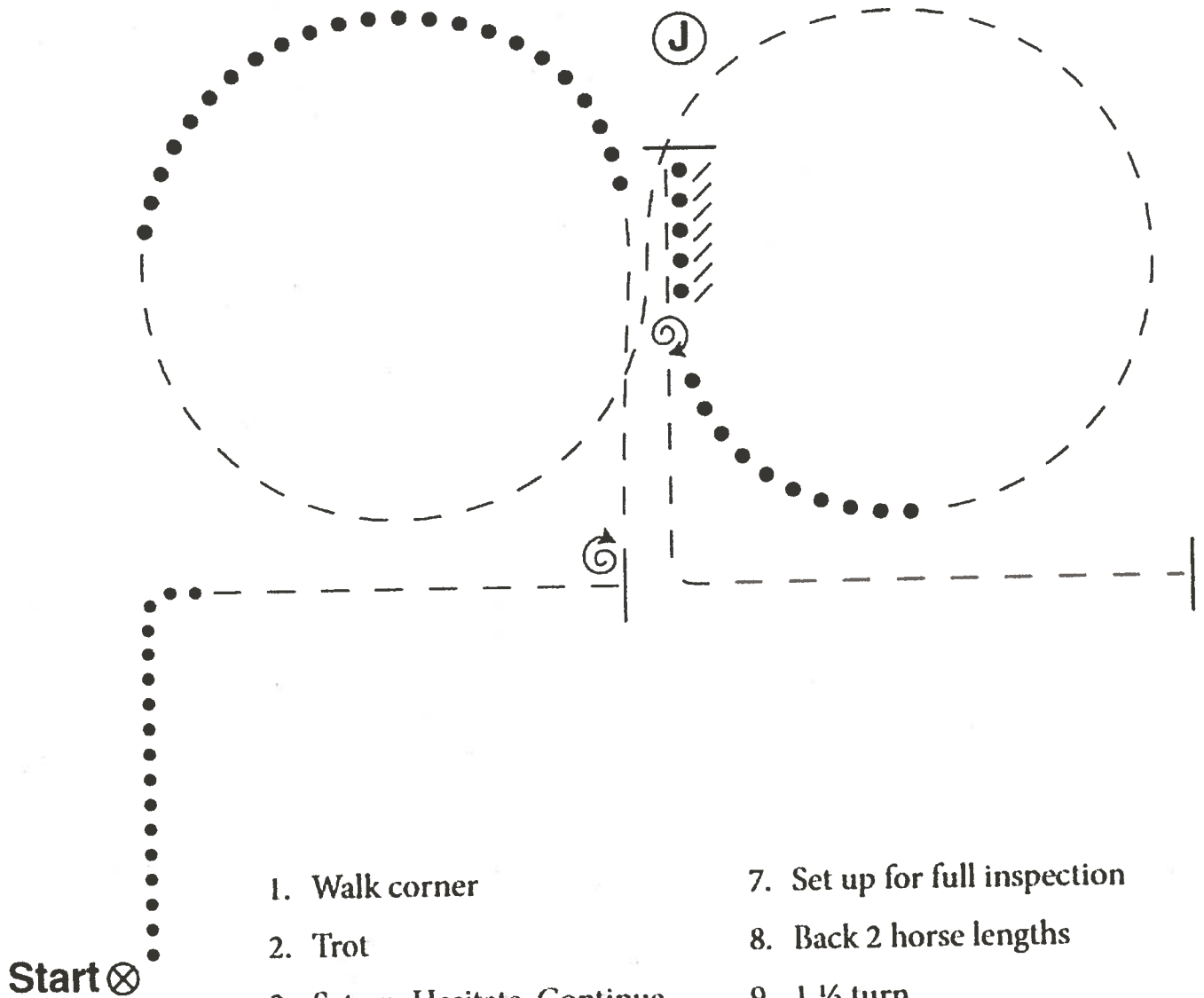

1. Walk corner
2. Trot
3. Set up. Hesitate. Continue
4.  $1\frac{3}{4}$  turn
5. Trot towards judge and walk; trot left circle as shown
6. Trot, walk, right circle and walk to judge
7. Set up for full inspection
8. Back 2 horse lengths
9.  $1\frac{1}{2}$  turn
10. Trot left corner and stop, no set up
11. Exit at walk or trot

Note: The drawn description of this pattern is only intended for the general depictions of the pattern. Contestants should utilize the arena space to best exhibit their horses.

# Bareback EQUITATION

#52 Youth #53 Non Pro

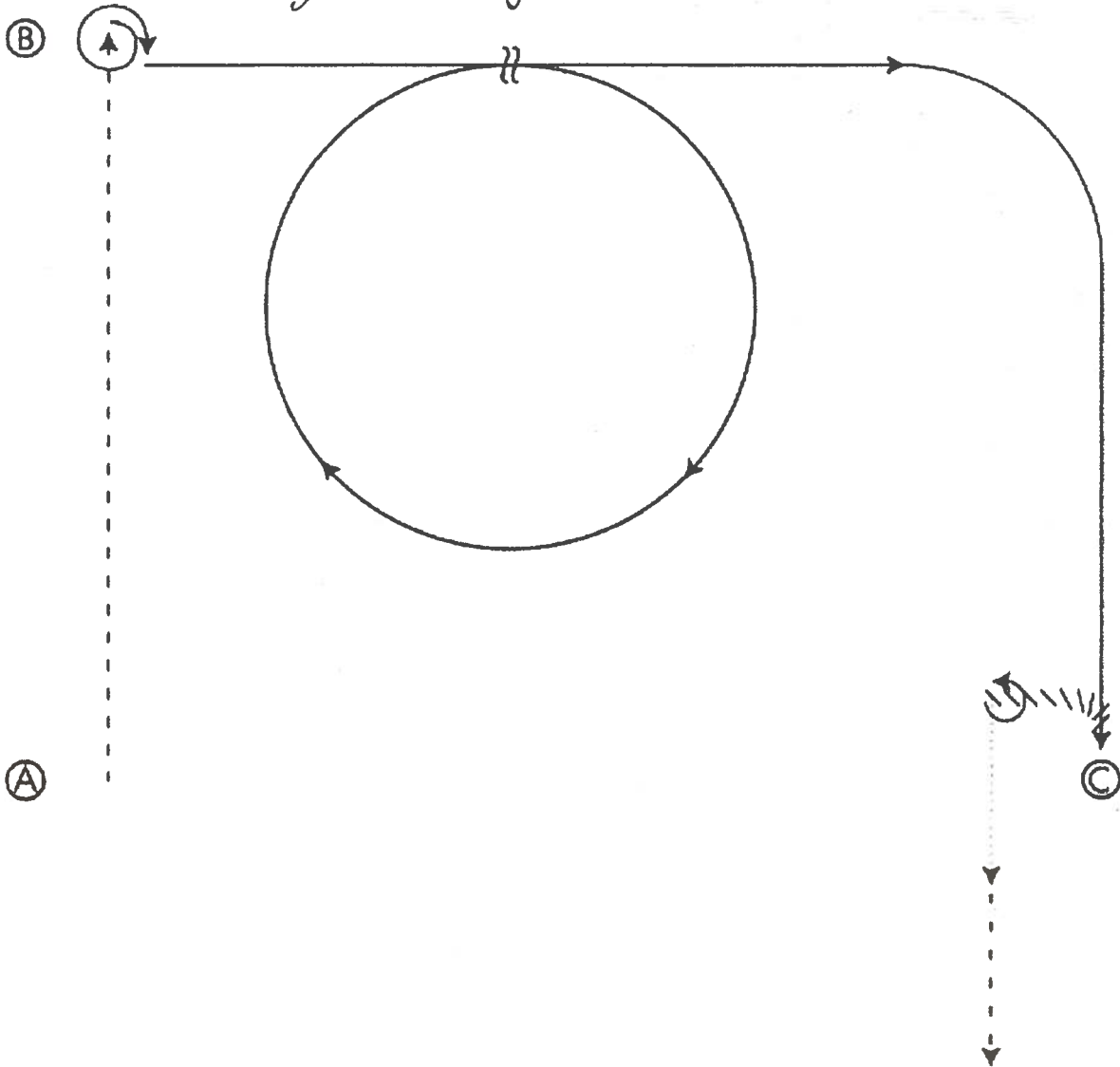

## KEY

## INSTRUCTIONS

.....

WALK

--- -- --

JOG

- . - . - .

EXTENDED JOG

—————

LOPE

//////////

BACK

≈

CHANGE LEADS

~~~~~

SIDEPASS

Ⓐ

MARKER

1. Begin at A. Jog from A to B.
2. At B, stop. Execute a 450-degree turn on the haunches to the right.
3. Lope in the right lead a circle to the right.
4. Change leads (flying or simple) and lope in the left (counter) lead an arc to the right to C.
5. At C, stop. Back an arc.
6. Execute a 270-degree turn on the forehand to the left.
7. Walk forward several steps. Pick up the jog and exit the arena at a jog.

# All Trail Classes Except Walk/Trot

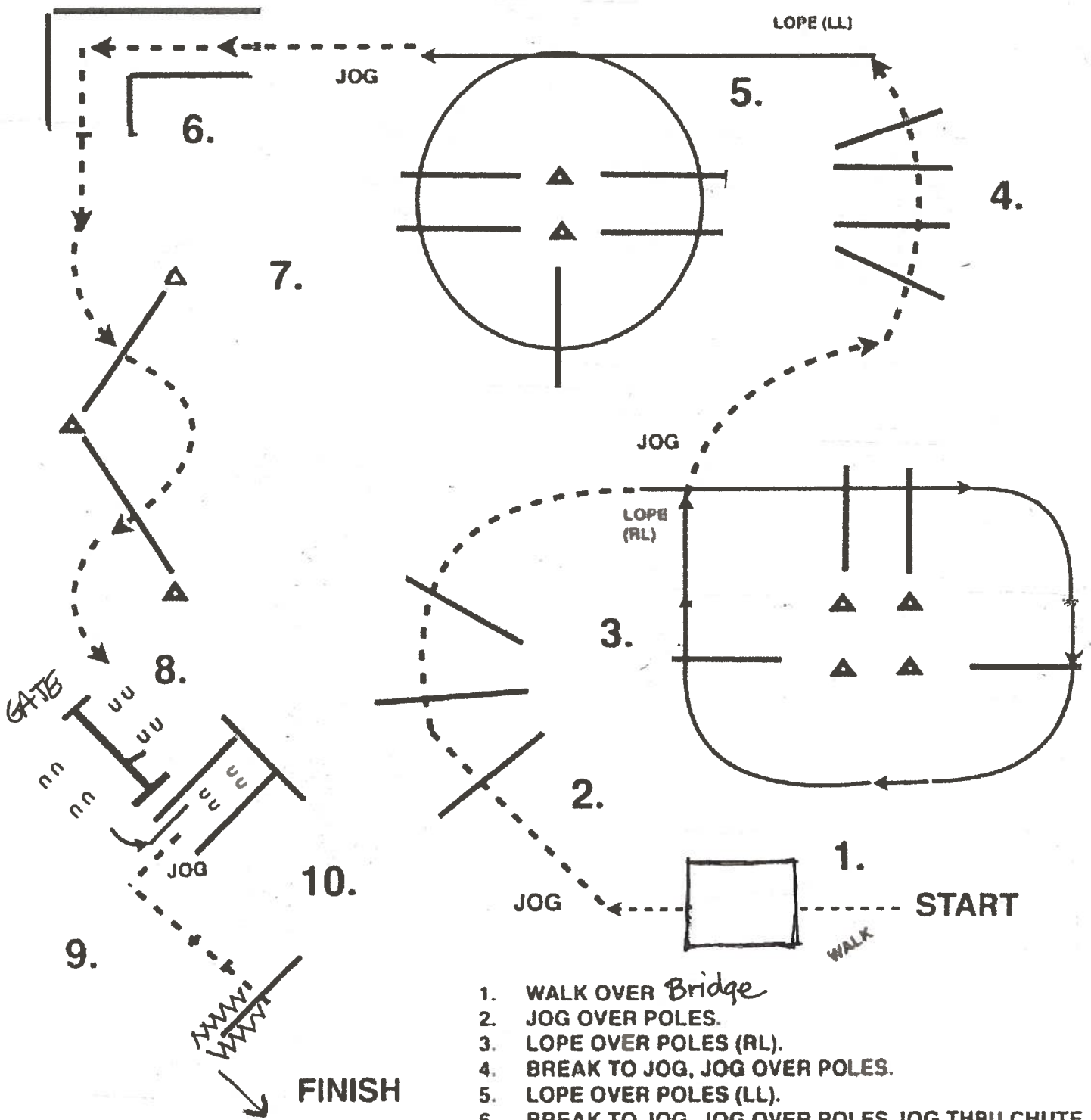

1. WALK OVER Bridge
2. JOG OVER POLES.
3. LOPE OVER POLES (RL).
4. BREAK TO JOG, JOG OVER POLES.
5. LOPE OVER POLES (LL).
6. BREAK TO JOG, JOG OVER POLES JOG THRU CHUTE.
7. JOG THRU SERPENTINE, JOG OVER POLES.
8. GATE: RH WALK OVER POLE, CLOSE GATE.
9. BACK THRU POLES.
10. JOG OUT CHUTE, to pole; side pass right; Walk to EXIT

# Trail-Walk/Trot + Yearling In Hand

#67 Youth 11-18  
 #72 Youth 10+U  
 #73 Non-Pro W/T  
 #75 Yearling in hand

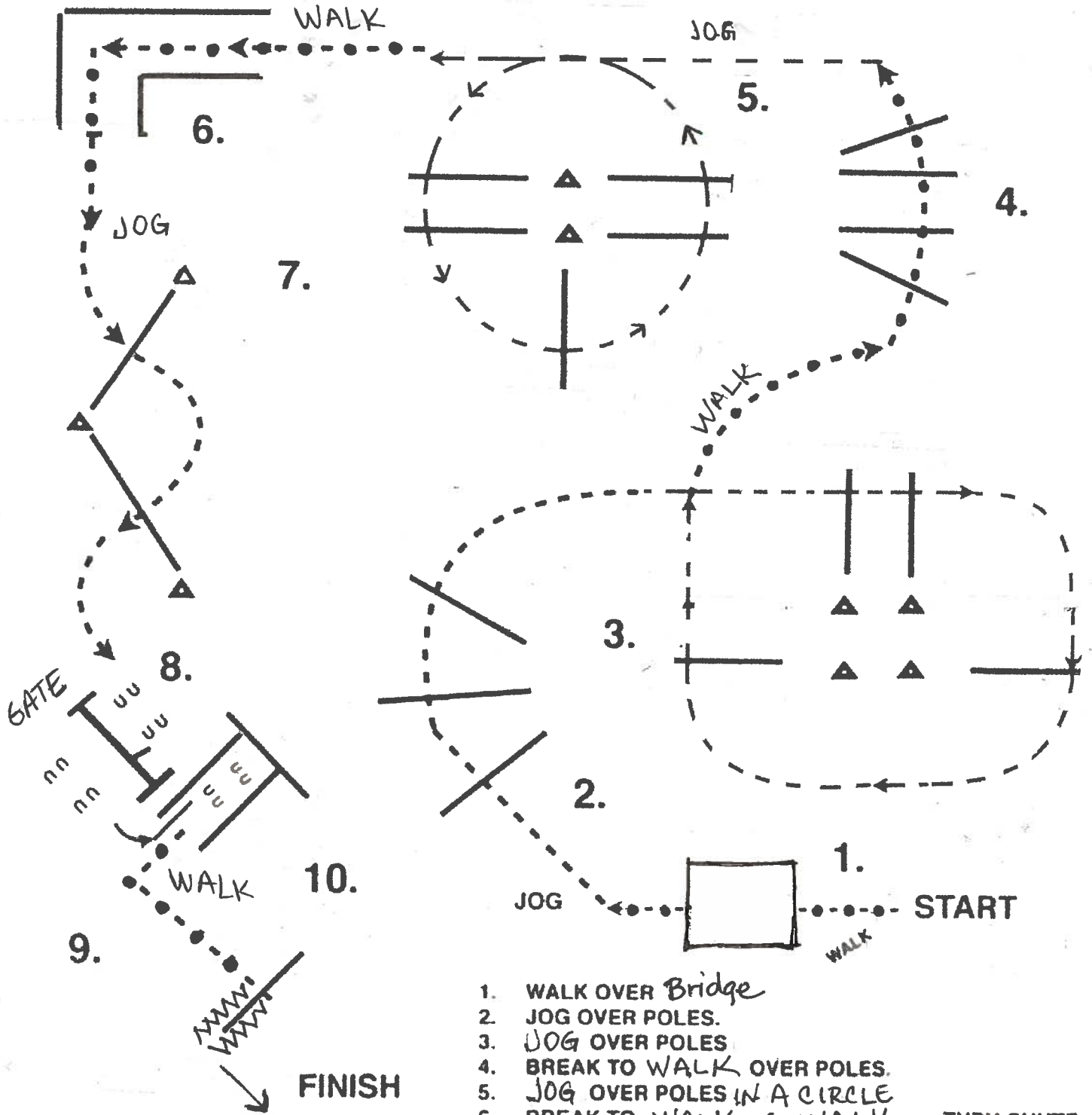

1. WALK OVER Bridge
2. JOG OVER POLES.
3. JOG OVER POLES
4. BREAK TO WALK OVER POLES.
5. JOG OVER POLES IN A CIRCLE
6. BREAK TO WALK ; WALK THRU CHUTE.
7. JOG THRU SERPENTINE, JOG OVER POLES.
8. GATE: RH WALK OVER POLE, CLOSE GATE.
9. BACK THRU POLES.
10. WALK OUT CHUTE, to pole; side pass right; walk to exit

# Western Horsemanship

(except Novice and Walk/Trot)

- #80 NP35+Over
- #81 Youth 18+U
- #82 Non Pro
- #87 Masters

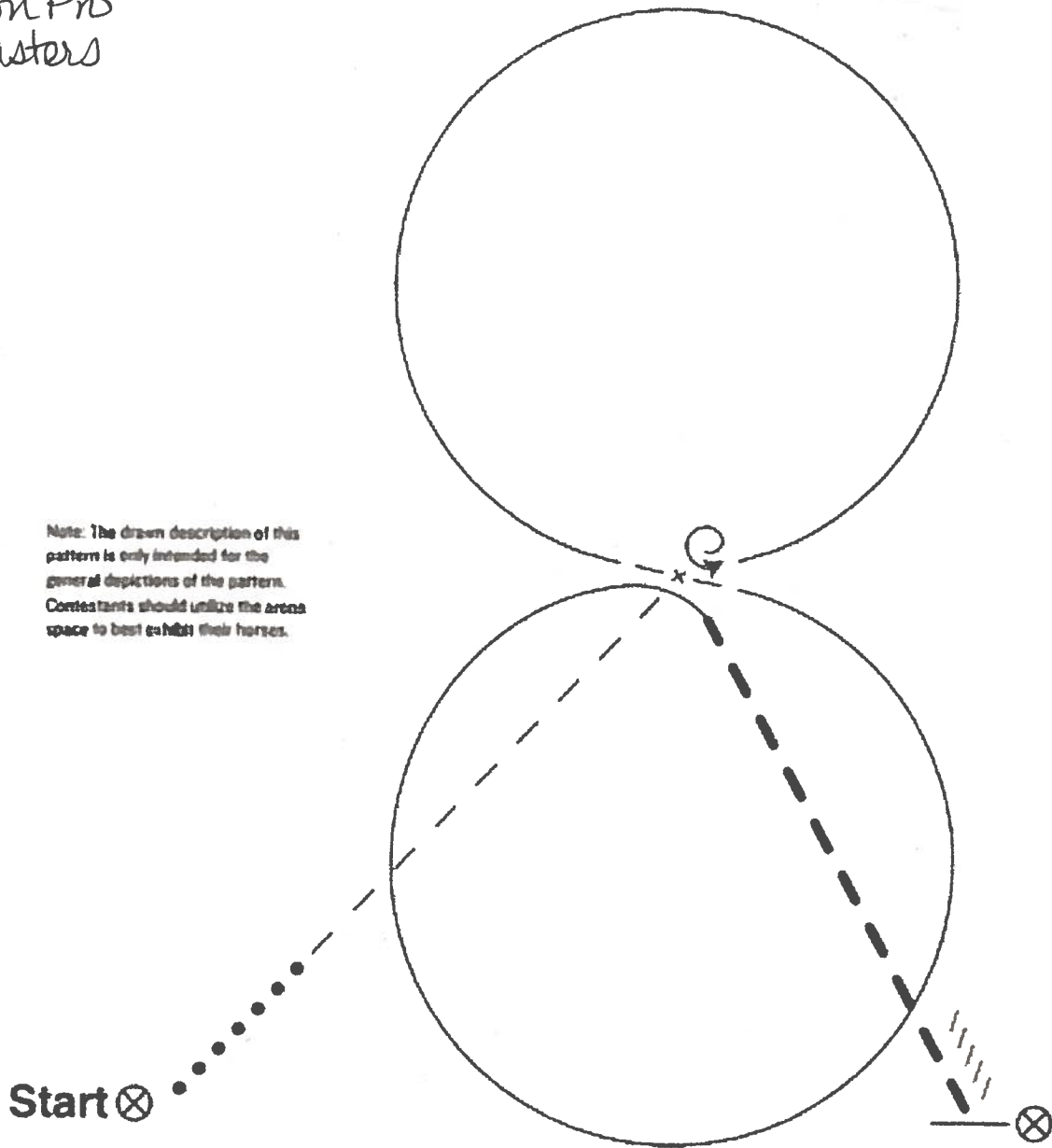

1. Walk approximately 15'
2. Jog to center
3. Stop. Execute an approximate  $\frac{1}{4}$  turn to the left
4. Lope, left lead circle
5. *FLYING* or simple lead change
6. Lope, right lead circle
7. Extended trot to marker
8. Stop & back
9. Exit at a walk or jog



# Novice Western Horsemanship

#84 Novice Non-Pro  
#85 Novice Youth

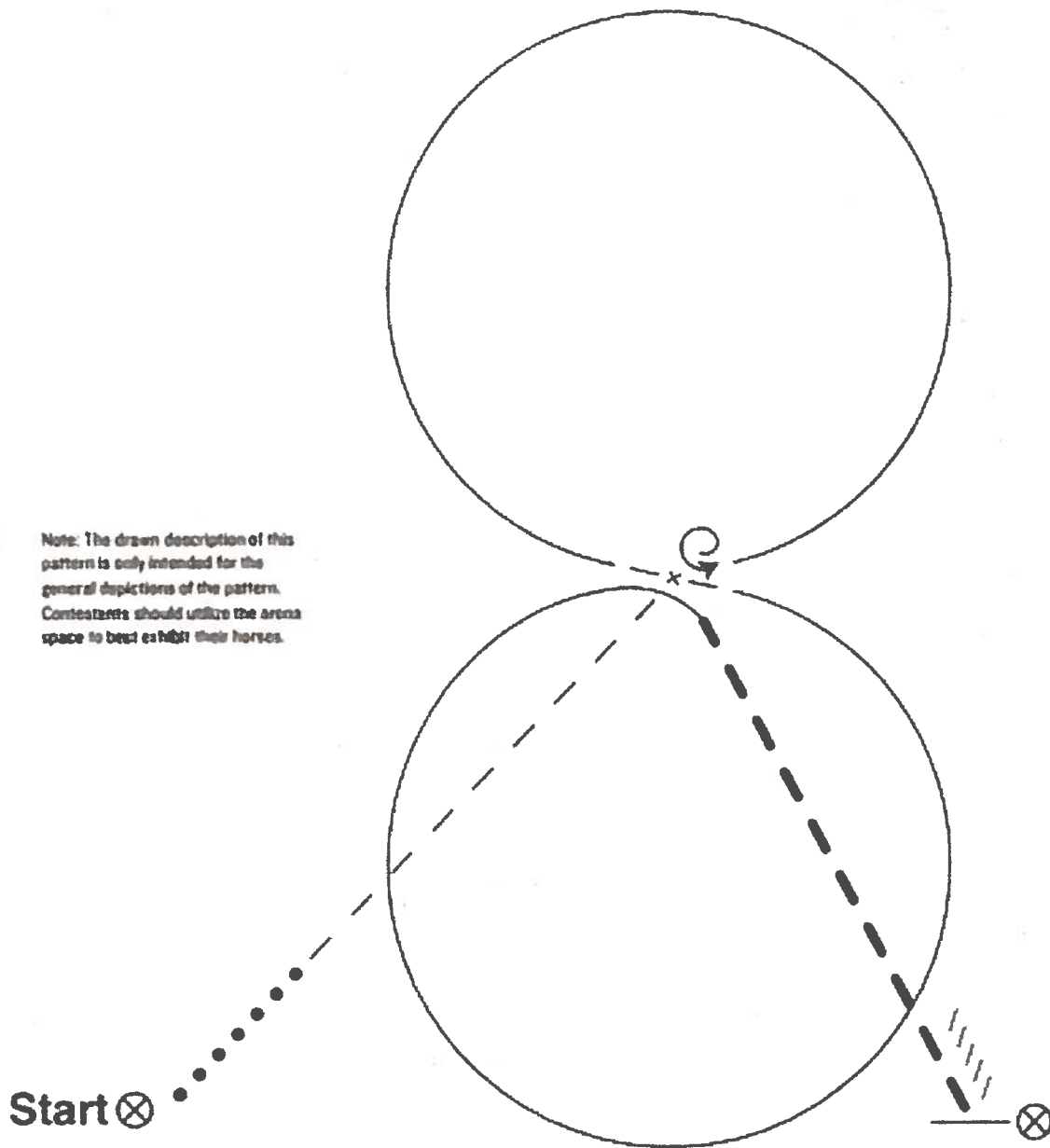

1. Walk approximately 15'
2. Jog to center
3. Stop. Execute an approximate  $\frac{3}{4}$  turn to the left
4. Lope, left lead circle
5. Simple change, through a jog
6. Lope, right lead circle
7. Extended trot to marker
8. Stop & back
9. Exit at a walk or jog

# Western Horsemanship Walk/Trot

- #83 Youth 11-18 W/T
- #86 NP W/T
- #79 Youth 10+ Under

Note: The drawn description of this pattern is only intended for the general depiction of the pattern. Contestants should utilize the arena space to best exhibit their horses.

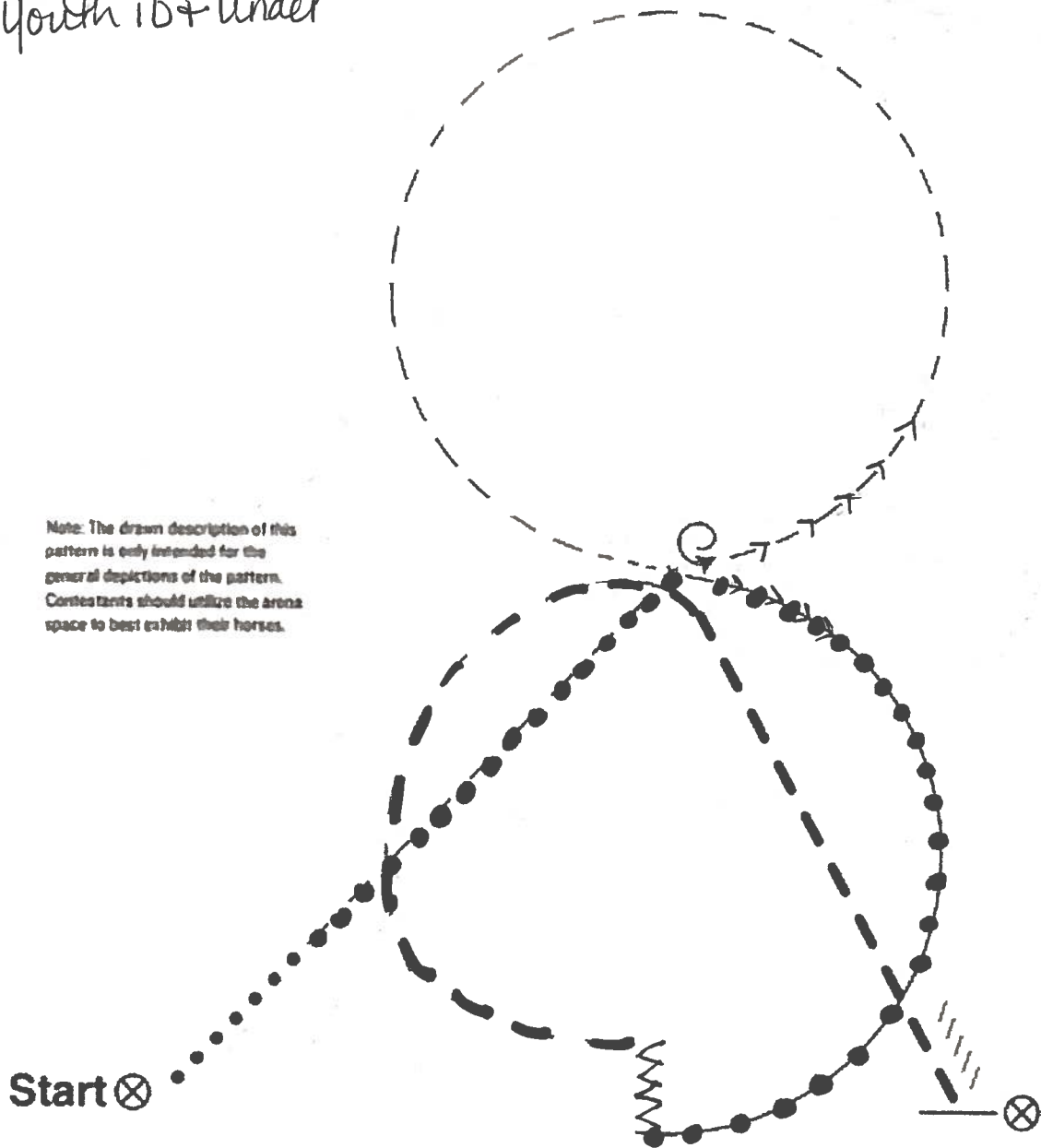

1. Walk to Center.
2. Stop.
3. Stop. Execute an approximate  $\frac{1}{4}$  turn to the left
4. Jog a circle to the left.
5. Stop
6. Walk  $\frac{1}{2}$  circle to right + side pass right
7. Extended jog to marker
8. Stop & back
9. Exit at a walk or jog

# Saddle Seat Equitation

#126 Non Pro

#127 Youth 18+ Under

W W W . H O R S E S H O W P A T T E R N S . C O M

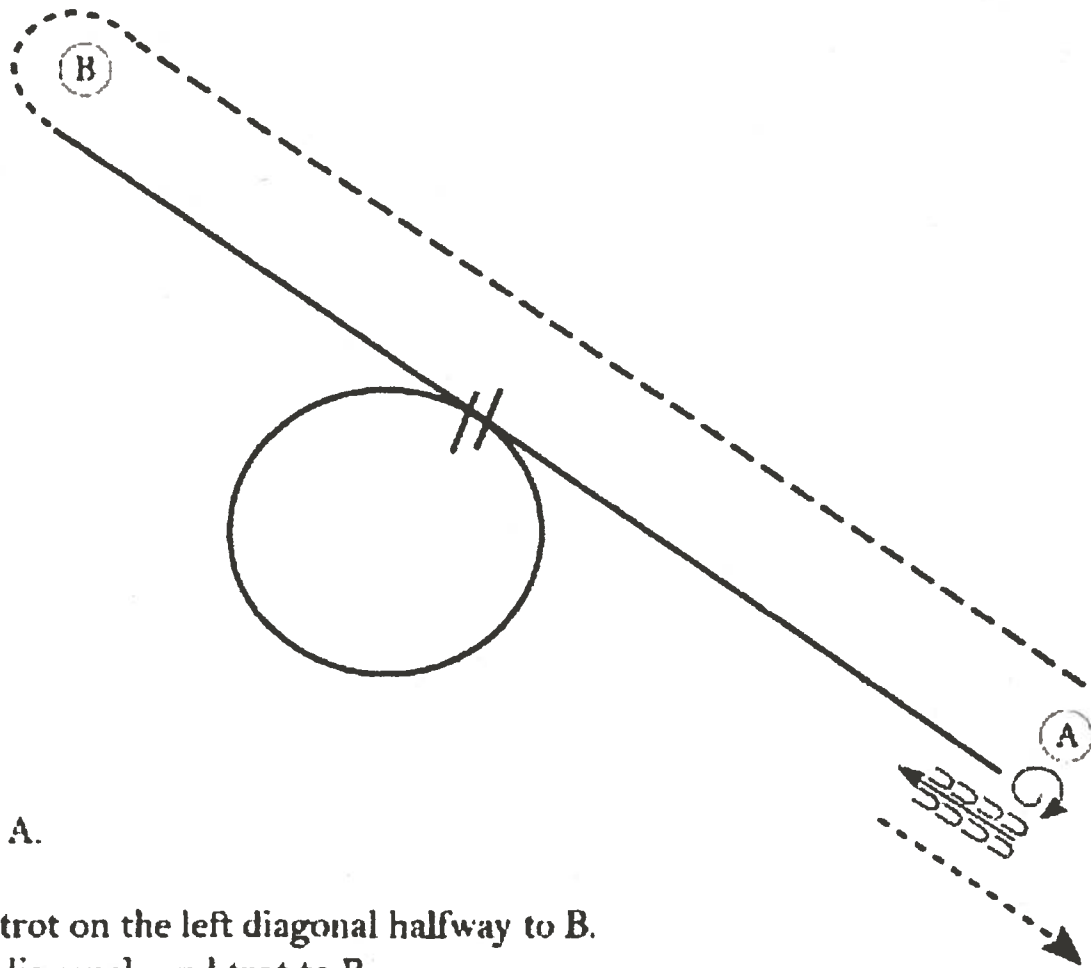

Be ready at A.

1. Posting trot on the left diagonal halfway to B.
2. Change diagonals and trot to B.
3. Break to the walk and walk around B.
4. Canter on the right lead halfway to A.
5. Continue to canter in a circle to the right.
6. Perform a simple lead change and canter to A.
7. Halt at A and perform a 360 degree turn on the forehand to the right.
8. Back approximately one horse length.

Pattern is over once you have backed. Walk off and follow the instructions of your ring steward.

|               |           |
|---------------|-----------|
| Walk          | .....     |
| Trot          | - - - - - |
| Extended Trot | — — — — — |
| Canter        | —————     |
| Leg Yield     |           |
| Lead Change   | ↔         |
| Back          | ←←←←←     |
| Marker        | ⊙ B       |
| Sidepass      | ◀▶        |
| Hand Gallop   | —————     |

# Ranch Trail Pattern - 1

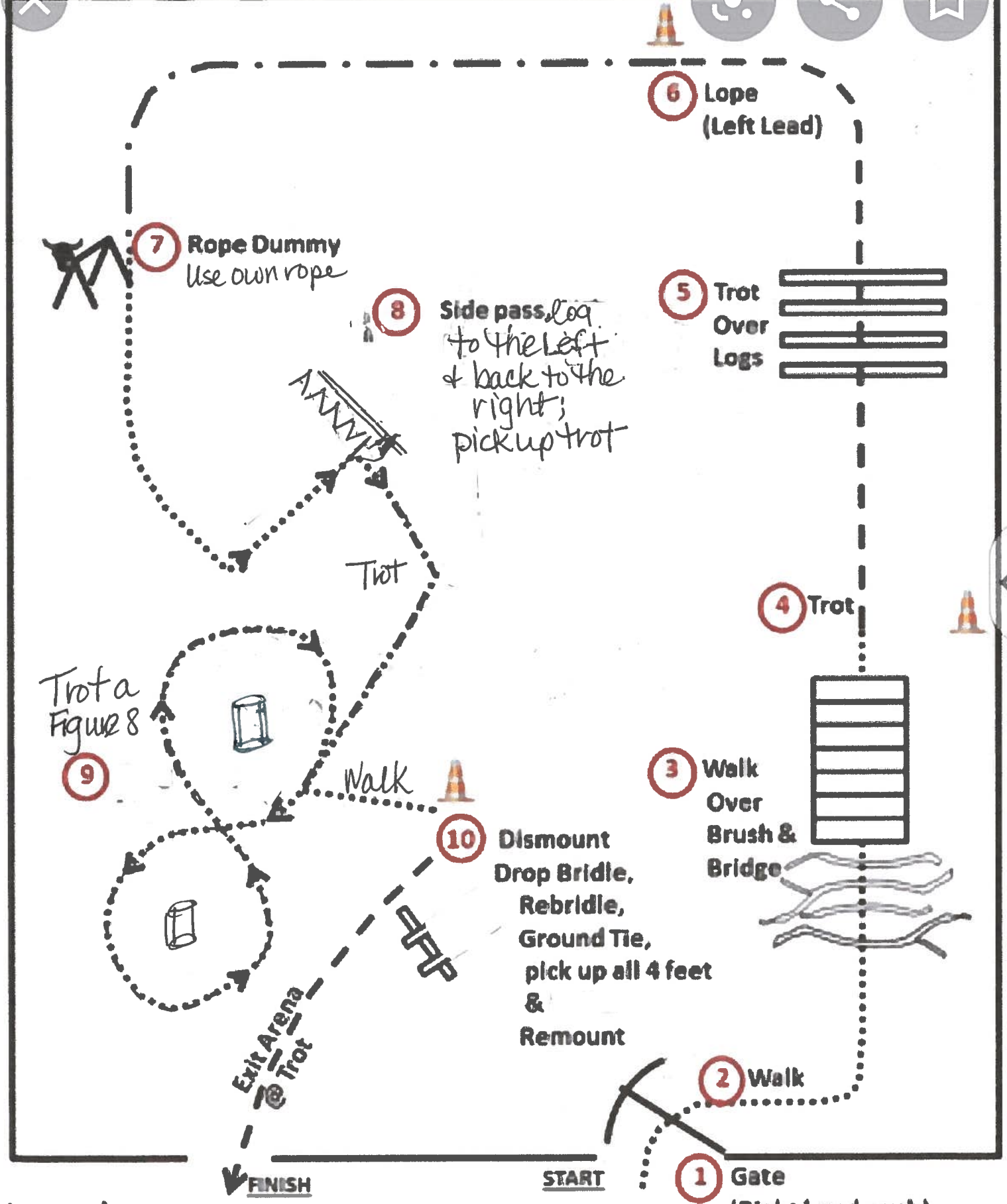
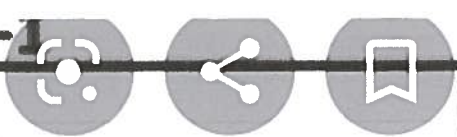

## Legend

|       |      |                     |      |
|-------|------|---------------------|------|
| ..... | Walk |                     | Cone |
| ----- | Trot | — . — . — . — . — . | Lope |

# ALL Ranch Horse Riding

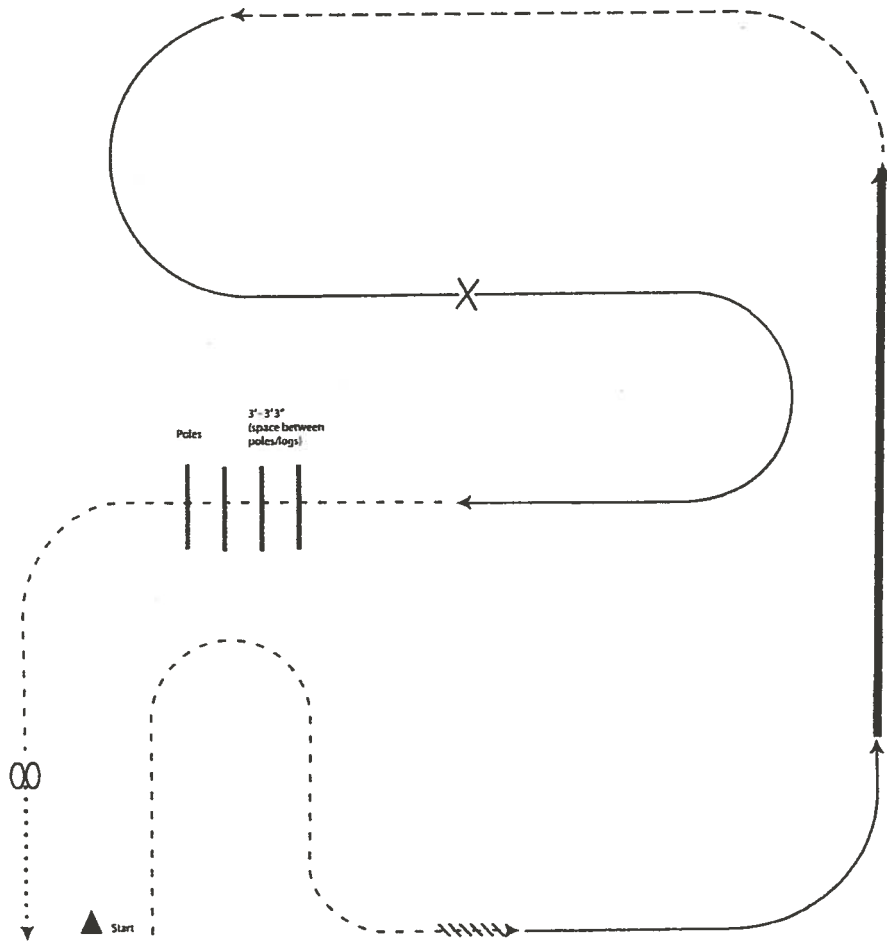

## KEY

- ..... Walk
- Trot
- - - - - Ext Trot
- Lope
- Ext Lope
- ////// Back
- X Lead Change
- 33 Sidepass
- ↓
- 33

## INSTRUCTIONS

1. Start at cone. Trot.
2. Stop
3. Back
4. Lope left lead
5. Extended lope
6. Extended trot
7. Lope left lead
8. Change leads (simple or flying)
9. Lope right lead
10. Trot over logs
11. Stop. Do 360-degree turn each direction.
12. Walk

# Ranch Reining - ALL CLASSES

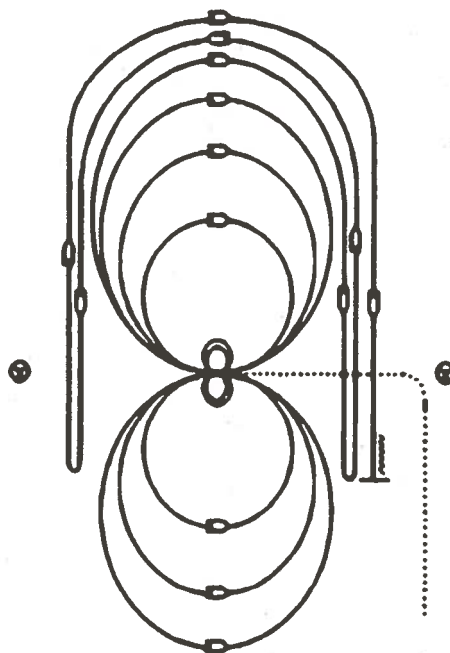

## RANCH REINING PATTERN 2

Mandatory Markers along Fence or Wall: The judge shall indicate with markers on arena fence or wall the center of pattern.

Ride pattern as follows: Trot to center of arena and stop or walk before departure.

1. Beginning on right lead, complete two circles to the right - the first one large and fast; the second one small and slow. Stop at center.
2. Complete 4 spins to the right. Hesitate.
3. Beginning on left lead, complete two circles to the left - the first one large and fast; the second one small and slow. Stop at center.
4. Complete 4 spins to the left. Hesitate.
5. Beginning on the right lead, complete a large fast circle to the right and change leads at center of arena. Complete a large fast circle to the left and change leads at center of arena.
6. Begin a large fast circle to the right, but do not close this circle. Run down the right side of the arena, past the center marker, and do a left roll back at least 20 feet from the wall or fence.
7. Continue back around the previous circle, but do not close this circle. Run down the left side of the arena, past the center marker, and do a right roll back at least 20 feet from the wall or fence.
8. Continue back around previous circle, but do not close this circle. Run down right side of the arena, past the center marker, and do a sliding stop at least 20 feet from the wall or fence. Back up at least 10 feet. Hesitate to show completion of pattern.

# All Reining Classes #143-148

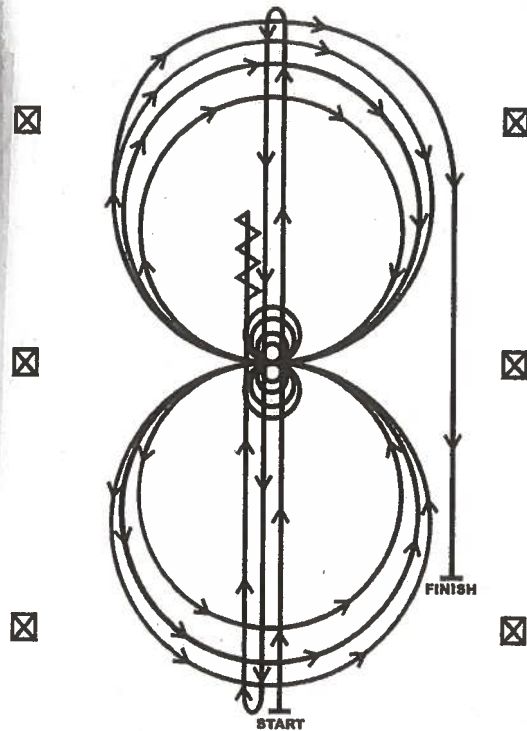

## PATTERN 7

1. Run at speed to the far end of the arena past end marker and do a left rollback - no hesitation.
2. Run to the opposite end of the arena past end marker and do a right rollback - no hesitation.
3. Run past the center marker, do a sliding stop. Back up to the center of the arena or at least 10 feet (3.05 m). Hesitate.
4. Complete four spins to the right.
5. Complete four and a one-quarter spins to the left so that horse is facing left wall or fence. Hesitate.
6. Beginning on the right lead, complete three circles to the right: the first two circles large and fast, the third circle small and slow. Change leads at the center of the arena.
7. Complete three circles to the left: the first two circles large and fast, the third circle small and slow. Change leads at the center of the arena.
8. Begin a large fast circle to the right but do not close this circle. Run straight down the right side of the arena past the center marker and do a sliding stop at least 20 feet (6.09 m) from the wall or fence. Hesitate to demonstrate completion of the pattern.

*Exhibitor may be requested to dismount and drop bridle to the designated judge.*

# Western Riding - ALL Classes

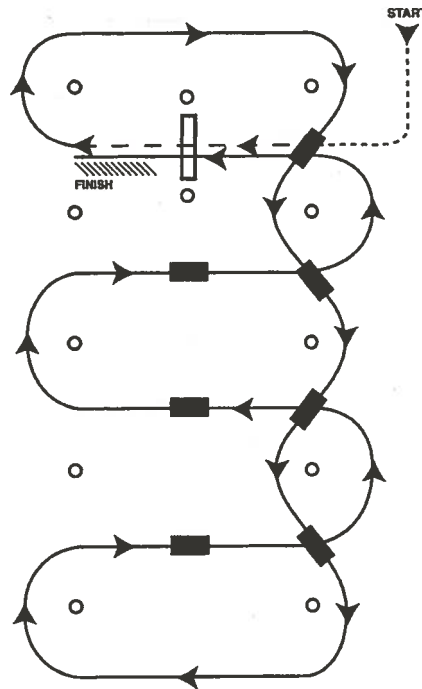

|                 |                             |
|-----------------|-----------------------------|
| WALK -----      | ○ MARKER                    |
| JOG - - - - -   | ■ RECOMMENDED CHANGING AREA |
| LOPE —————      | ▭ LOG                       |
| BACK ▨▨▨▨▨▨▨▨▨▨ |                             |

## WESTERN RIDING PATTERN 4

1. Walk, transition to jog, jog over log
2. Transition to right
3. First line change
4. Second line change
5. Third line change
6. Fourth line change
7. First crossing change
8. Second crossing change
9. Third crossing change
10. Lope over log
11. Lope, stop & back



# English Showmanship

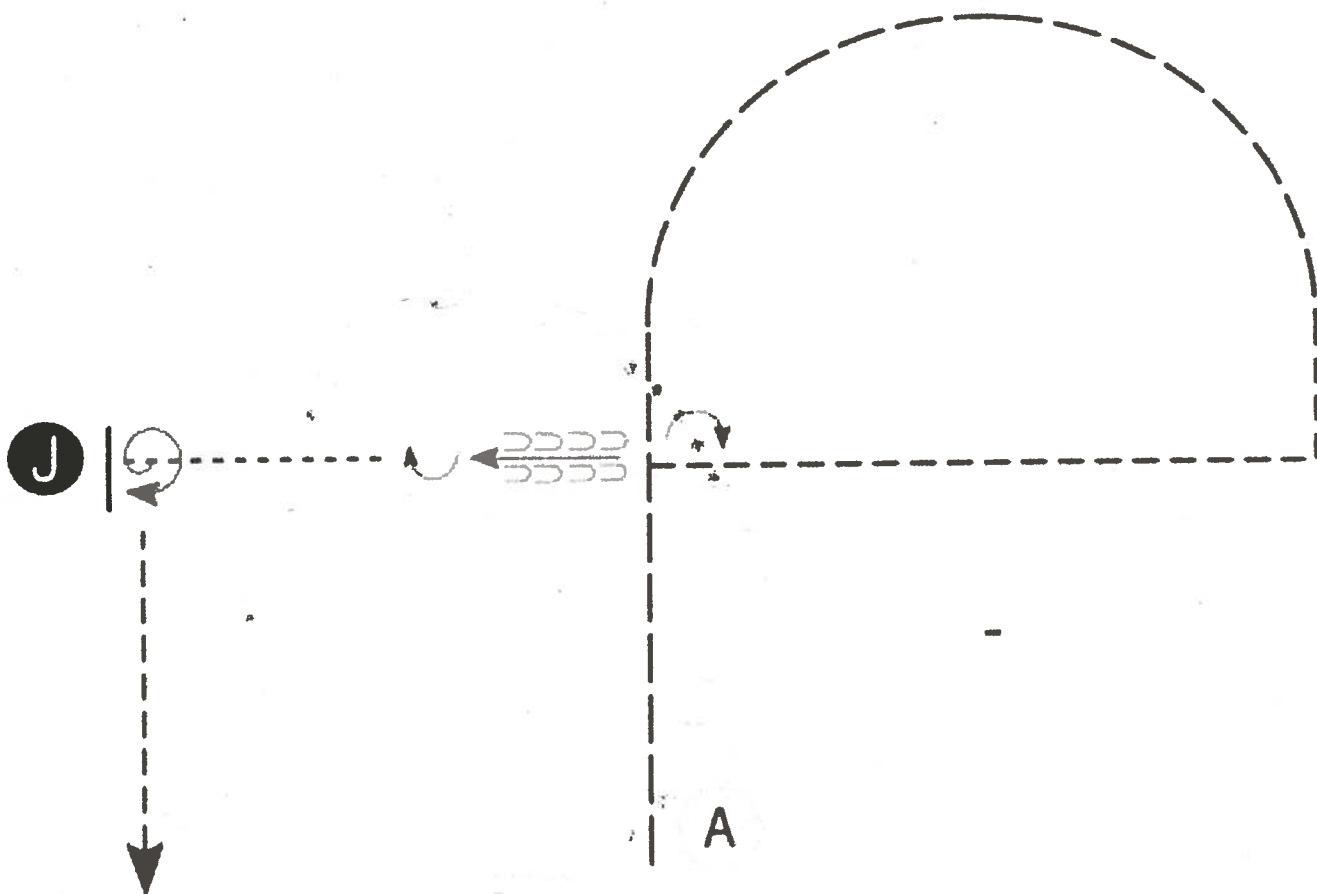

Be ready at A.

1. Extend trot straight ahead then 1/2 circle.
2. Slow trot before square corner and continue to center of pattern.
3. Stop, perform a 1/2 turn and back two horse lengths.
4. Stop, perform a 1/2 turn and walk.
5. Stop, set up for inspection.
6. Perform a 1 3/4 turn and trot away.

Pattern ends after passing marker A.

|        |        |
|--------|--------|
| Walk   | .....  |
| Trot   | -----  |
| Back   | ←----- |
| Marker | B      |
| Judge  | J      |

# Hunt seat Equitation

(except Novice + Walk/Trot)

#178 NP 35+Over  
#179 Youth 18+U  
#180 Non Pro

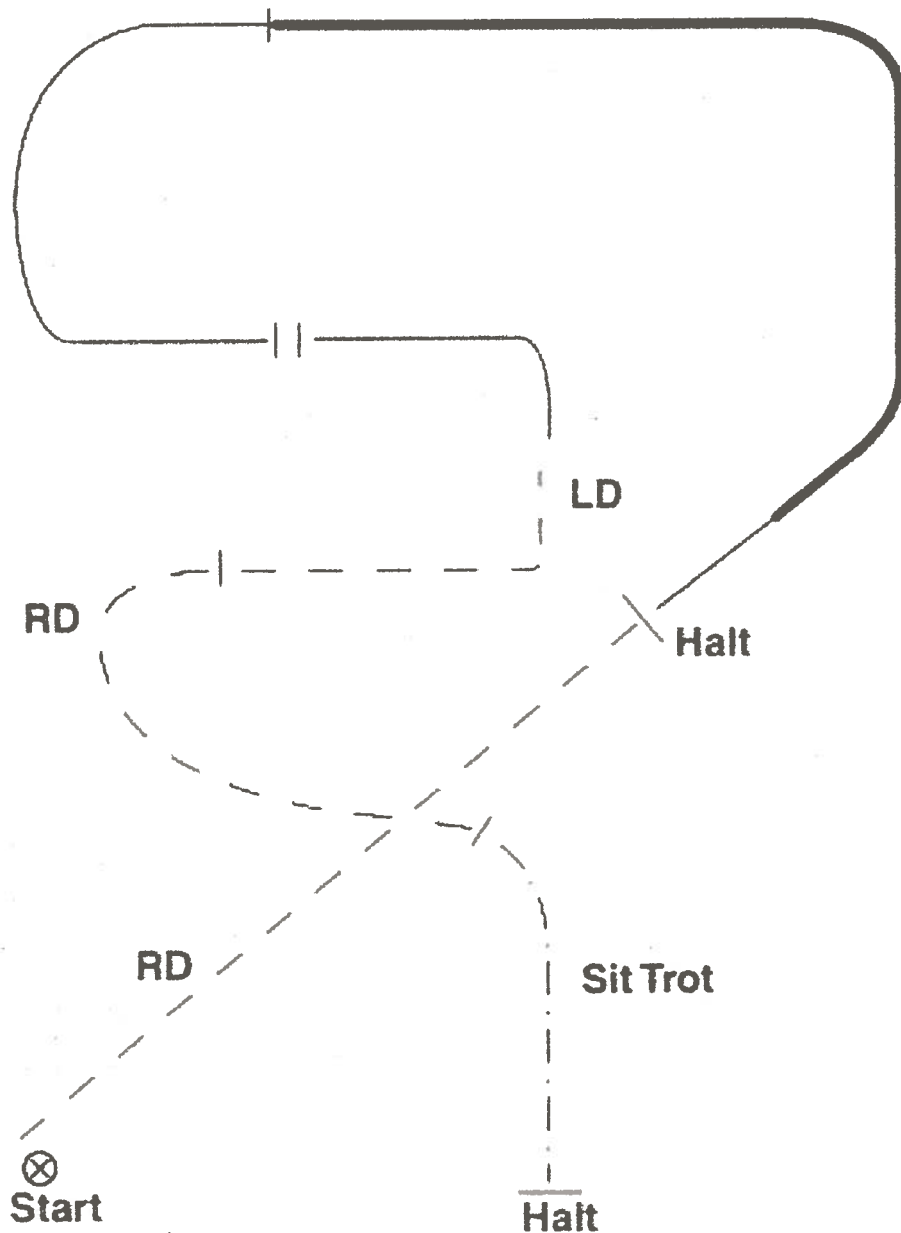

1. Right diagonal. Halt
2. Left lead moving into a hand gallop as shown
3. Collect the left lead and follow path as shown
4. Change leads, right lead
5. Left diagonal trot
6. Right diagonal trot
7. Sit trot. Halt
8. Exit at a walk and trot

# Huntseat Equitation-NOVICE

#182 Novice Non Pro  
 #183 Novice Youth

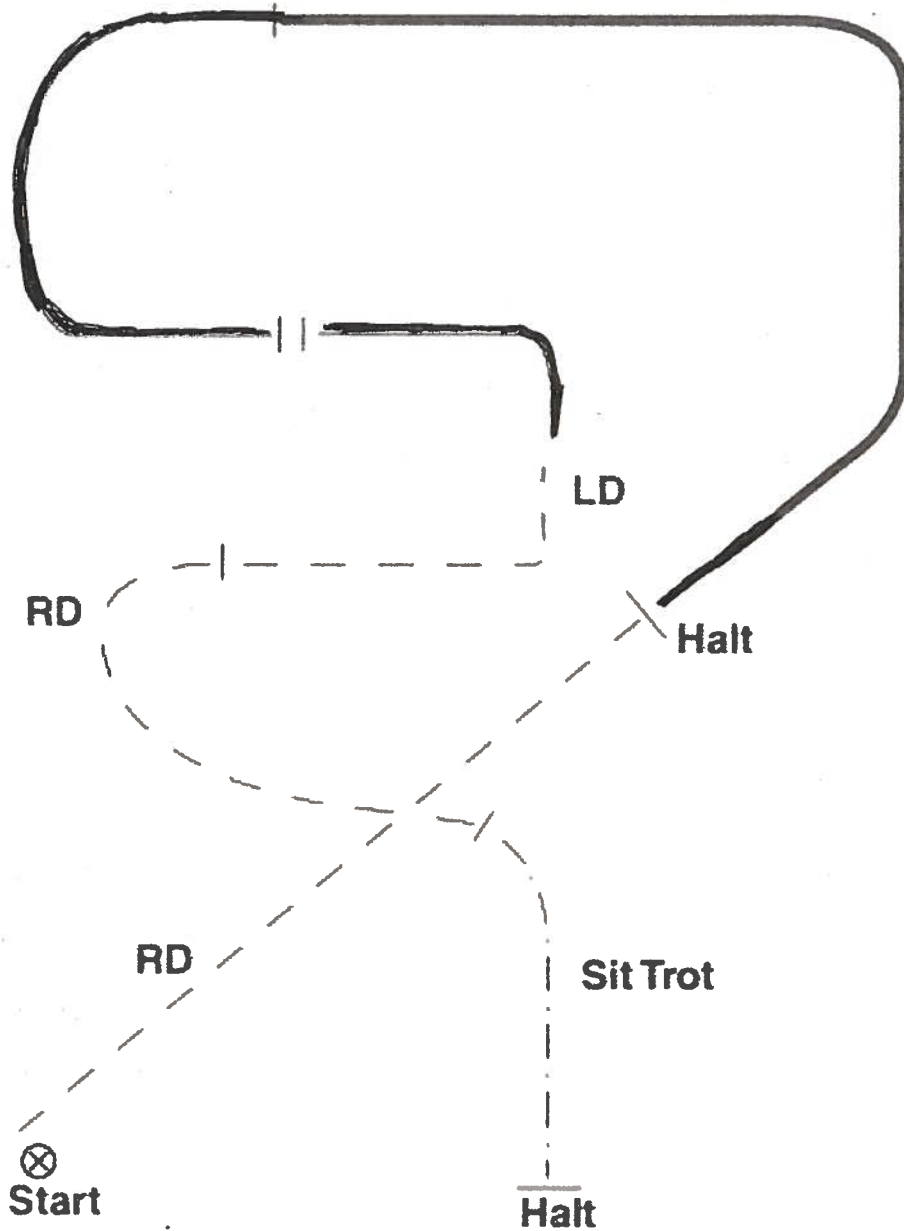

1. Right diagonal. Halt
2. (Not used)
3. ~~CANTER LEFT~~ lead and follow path as shown Simple lead change to right lead
4. (not used)
5. Left diagonal trot
6. Right diagonal trot
7. Sit trot. Halt
8. Exit at a walk and trot

# Huntseat Equitation Walk/Trot

#197 Youth 11-18  
#200 NonProwIT  
#202 Youth 10+U

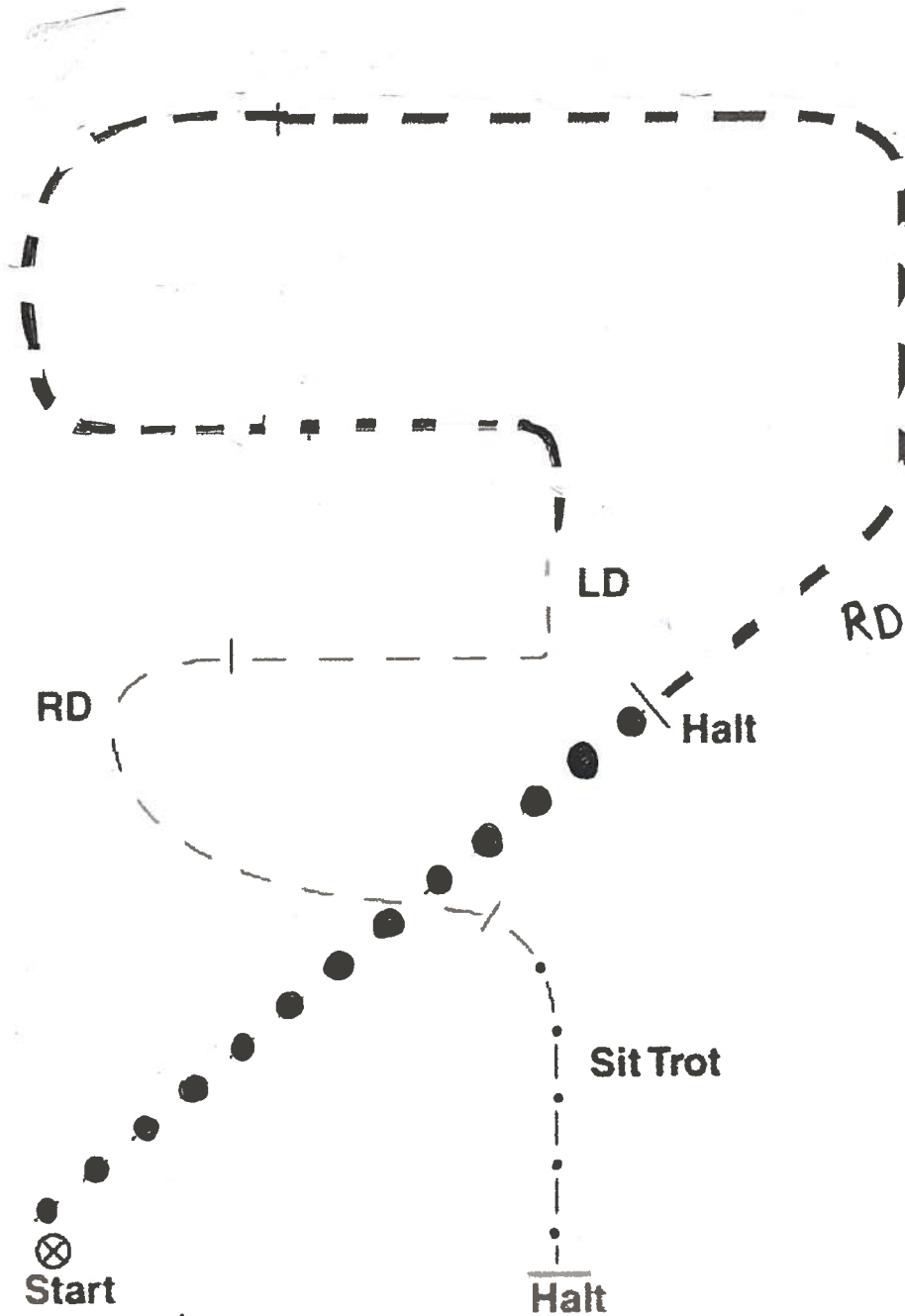

1. Walk, Halt
2. (Not used)
3. Trot Right Dia and follow path as shown
4. (not used)
5. Left diagonal trot
6. Right diagonal trot
7. Sit trot. Halt
8. Exit at a walk and trot

Miniature  
Horse Patterns  
to be determined